



MA STAR triple safety ★★★★★

This 5-star lift lives up to its name!

- ★ A sturdy and solid design
- ★ Safe usability
- ★ Simple maintenance and service
- ★ Simple installation
- ★ Intuitive operation



made by MAHA

 made
in
Germany

★ A STURDY AND SOLID DESIGN (ORIGAMI TECHNOLOGY)

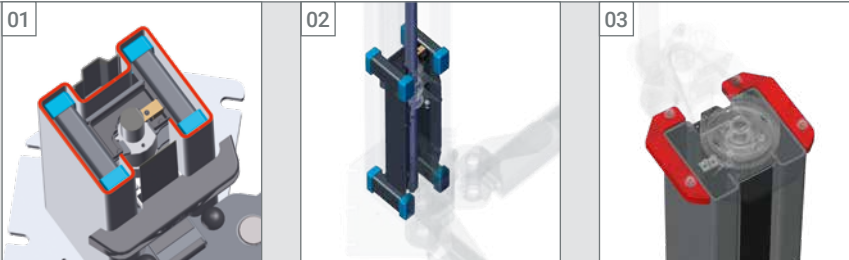

01
Maximum precision thanks to industrially rolled H-profile columns (origami technology, weld-free!) MA STAR 3.5 – patent pending.

02
Optimum load distribution thanks to almost wear-free sliding blocks rail-guided in the H-profile (8 pieces per column with up to 24 contact surfaces).

03
Highly stable and torsion-free column design thanks to additionally welded column collar.

★ SAFE USABILITY (TRIPLE SAFETY)



04
Tried-and-tested spindle-nut package with self-locking thread and 5-year commercial warranty*.

05
Unique patented "Giraffe" nut breakage detection.

06
Triple safety thanks to motor brake. Overrun no longer possible.

★ SIMPLE MAINTENANCE AND SERVICE (QUICK & EASY)



07
Highly service-friendly thanks to easy-to-access cable duct in H-profile on the outside.

08
Simple visual error diagnostics thanks to LEDs mounted on the circuit board.

09
Straightforward lubrication of the spindle as container filled with oil.

MA STAR 3.5

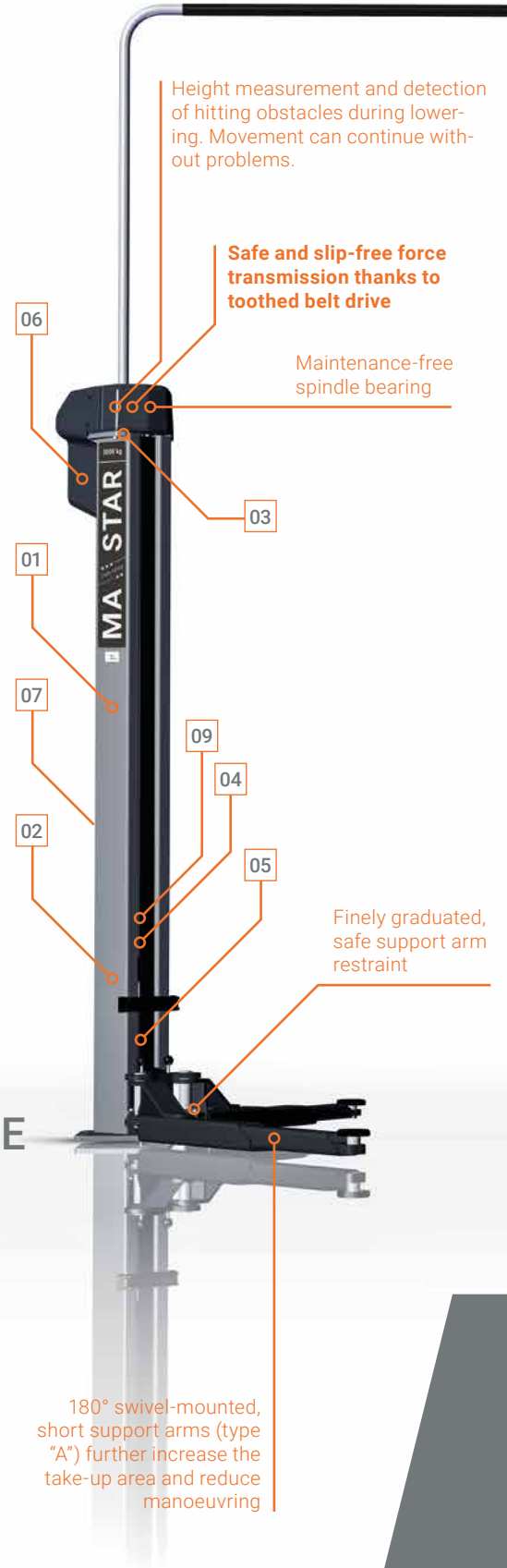

* Please note the detailed warranty terms included in the operating instructions.

MA STAR 5.5 / 6.5

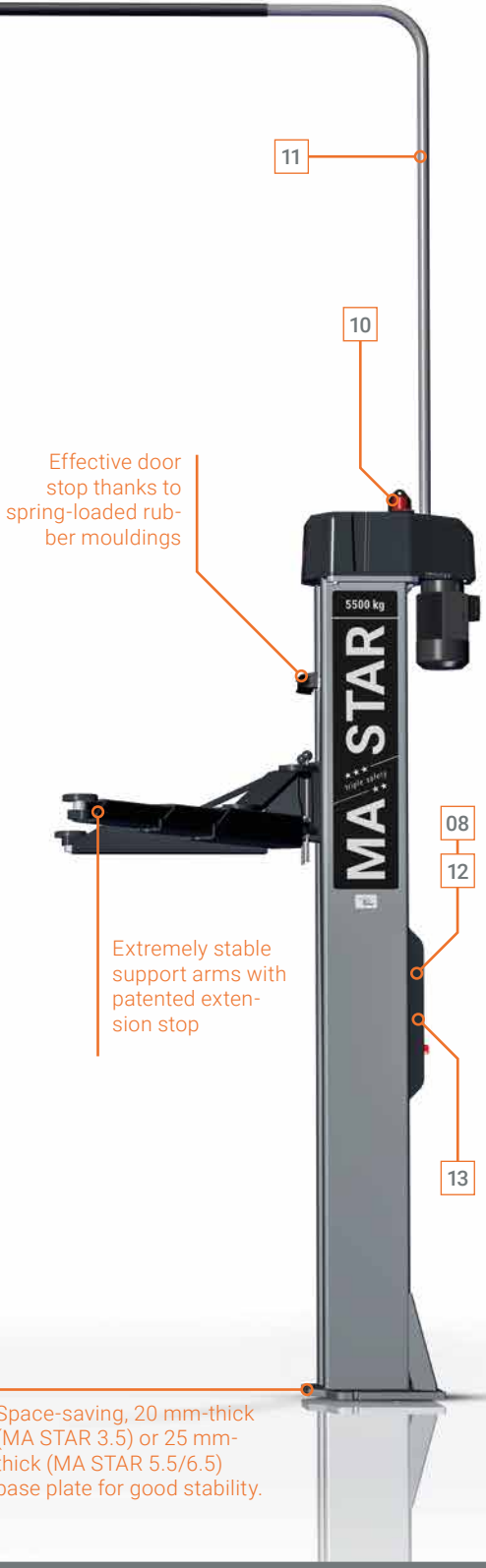

Effective door stop thanks to spring-loaded rubber mouldings

Extremely stable support arms with patented extension stop

Space-saving, 20 mm-thick (MA STAR 3.5) or 25 mm-thick (MA STAR 5.5/6.5) base plate for good stability.

★ SIMPLE INSTALLATION (PLUG & PLAY)



MA STAR = plug & play. All power cables pluggable incl. automatic rotating field detection (no specialist electrician needed).

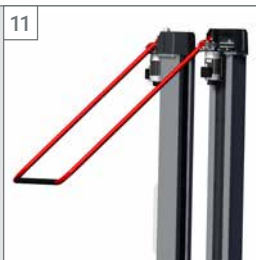

The patented folding cable bridge simplifies installation and significantly reduces set-up time. No work platform needed.

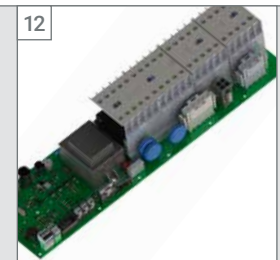

All sensors and options (second control unit, photoelectric ceiling barrier) with electric supply can be plugged into circuit board (plug 'n' play).

★ INTUITIVE OPERATION (LED-BASED)



Upper end position or photoelectric ceiling barrier reached. Only lowering is possible. Lower button lights up blue.



Lower end position reached or an obstacle has been hit. Only lifting is possible. Raise button lights up blue.



Sensor malfunction. Signal light flashes red.



for cars and vans up to 3,5/5,5/6,5 t total weight



FURTHER ADVANTAGES (NO HYDRAULIC OIL, NO LEAKAGE)



Large door opening for easy exit from the vehicle thanks to 45° rotated columns (MA STAR 3.5 A).

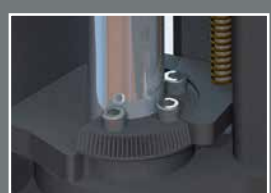

Maximum safety thanks to arched support-arm restraint with operation across the entire length with small ratchet graduation.



Support arms pivot directly above the floor, which enables a very low minimum pad height.



Can hold vehicles from mini-cars to vans (e.g. SMART fortwo and VW T6 long 3.5 t resp. up to MB Sprinter and VW Crafter long wheelbase 5.5/6.5 t).

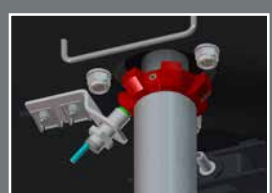

Height measurement via touchless, non-wearing inductive proximity switches.

OPTIONS



Second control unit on opposite column means less walking around the lift.



Energy set for control unit:
2 x 230 V power socket
1 compressed-air coupling



Sheet metal tray for support disc extensions.



Impact wrench holder with integrated tray for support disc extensions.



Document holder for practical storage of instruction manuals, work orders, etc.



Magnetic wheel nut trays.



Special supports and slip-proofing – flexible and secure.



Support disc extensions in five different lengths:
50/100/150/200/300 mm
(300 mm only for MA STAR 5.5/6.5)

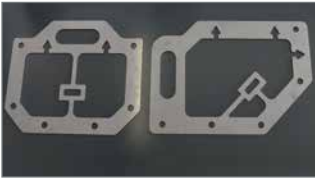

Drilling template for straight-forward set-up.



Installation anchors incl. cartridge
(one anchor length for all floors).



LED illumination.



Set-up device for columns
(MA STAR 3.5 A/S).



Protection stop for vehicles with low doors (MA STAR 3.5 A/S).



Wheel support forks for special and electric vehicles (MA STAR 5.5/6.5).



Sports car support arms with 80 mm minimum pad height (MA STAR 3.5 A Comfort).



Support arm assist by double roller spring bearing on top/bottom side (MA STAR 5.5/6.5 Comfort – patent pending).

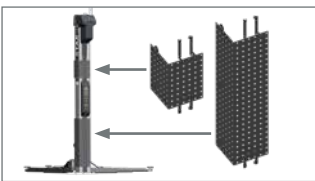

Perforated plate module, L-shaped, for Hoffmann GARANT Easyfix tool storage system (MA STAR 3.5 A/S).

Picture credits: Title page: © evannovostro – Adobe Stock

BR364511-en 03 - Drawings and details are not binding. Prices are subject to change without notice. This leaflet supersedes previous editions.